

Ljunggren Audio Roll Your Own Ampmix

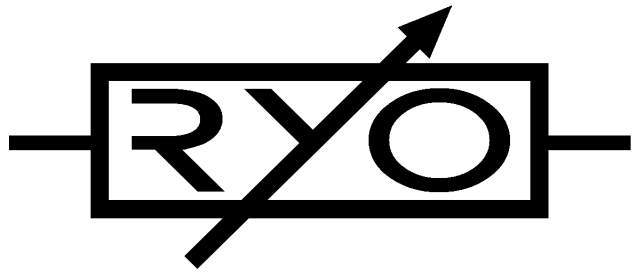

Version: Amplifying mixer/att 1.0

Bill Of Material

TYPE	PART	VALUE	PCS	NOTE
Resistor	R5,R6,R7,R8,R9,R10,R11, R12,R22,R23	10K	10	1,00%
Resistor	R13,R14,R15,R16,R17, R18,R19	1K	7	1,00%
Resistor	R20,R21	2K	2	1,00%
Resistor	R1,R2	10R	2	
Resistor	R3	33K	1	
Resistor	R4	4.7K	1	
Diode	D1,D2	SB130	2	Schottky power polarity protection
Capacitor	C1,C2,C5,C12,C13,C14, C15,C16,C17	100nF	9	Ceramic X7R 2.5mm pin pitch
IC Socket	IC1,IC2	14 pin	2	
OpAmp	IC1,IC2	TL084	2	or TL074
IC Socket	IC3	8 pin	1	
OpAmp	IC3	TL082	1	or TL072
Electrolytic	C3,C4	10 μ F	2	2mm pin pitch, 5mm dia, 5mm height
Trimmer	TRIM1	10K	1	Offset voltage calibration
Power header	POWER	10 pin	1	boxed
Jack	J1,J2,J3,J4,J5,J6,J7,J8	3.5mm	8	PJ301BM
Rotary Pot.	POT1,POT2,POT3,POT4	50K lin	4	or 100K lin
Knobs	Small fluted skirtless	cream	4	
Screws	Black, Pozi	M3x6	2	Mounting screws
PCB			1	
Faceplate	PCB material (FR4)	black	1	

Assembly instructions

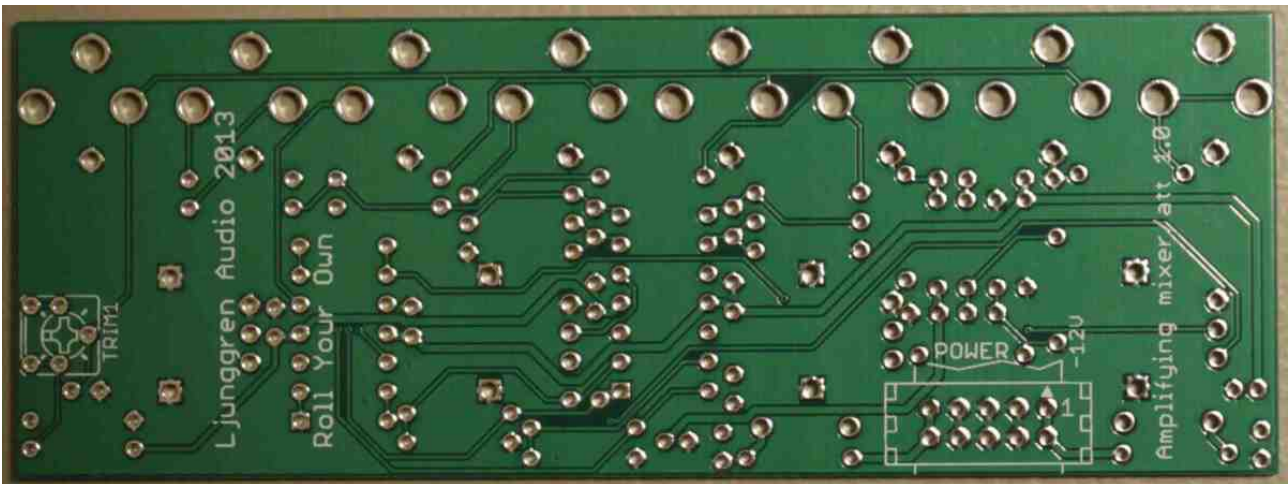

Empty PCB bottom.

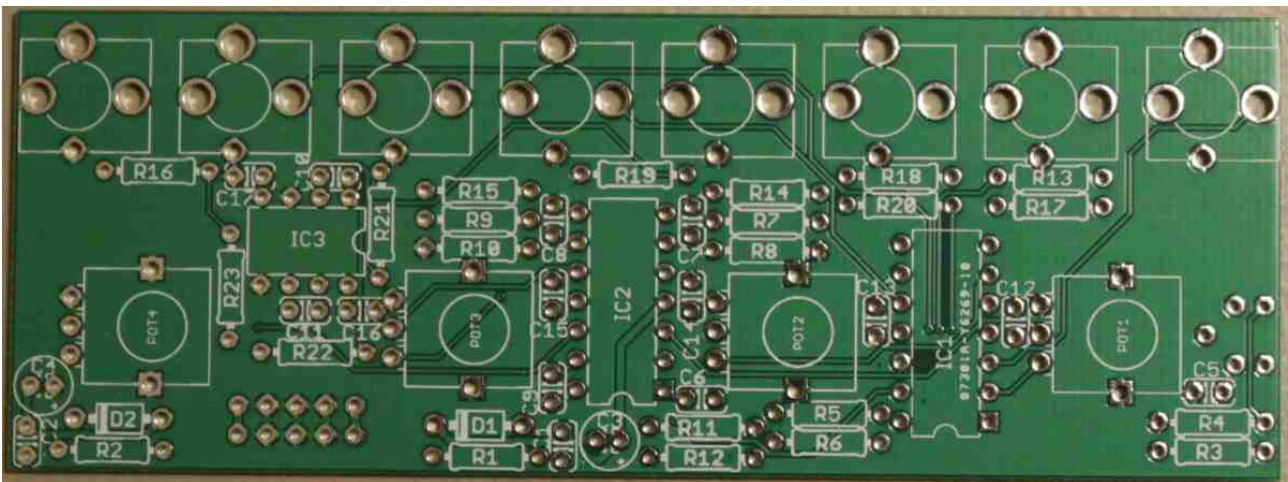

Empty PCB top.

Step 1

Solder resistors. Resistors are not sensitive to mounting direction.

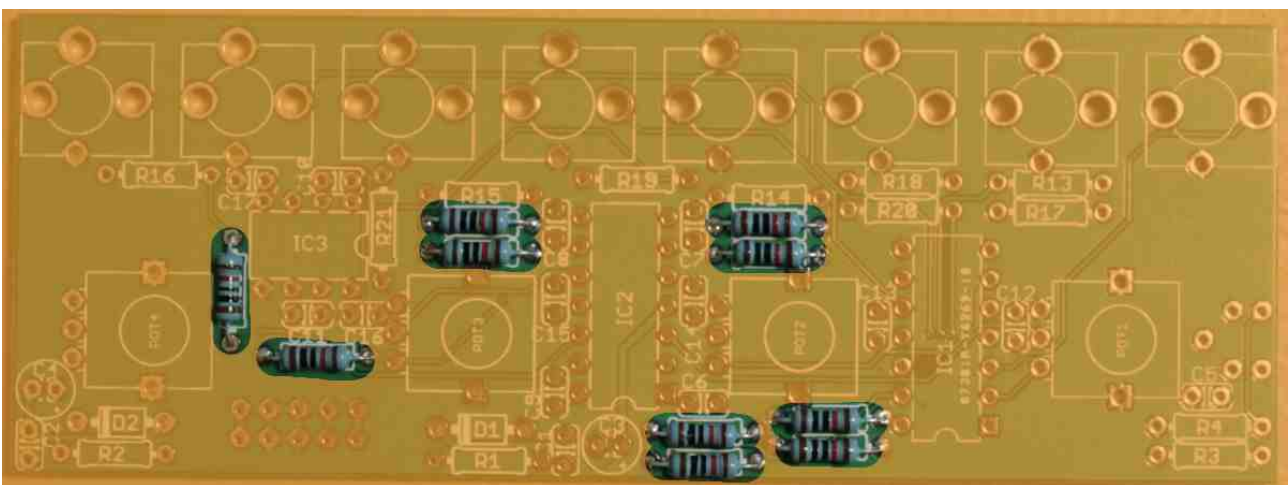

R5, R6, R7, R8, R9, R10, R11, R12, R22, R23 10K

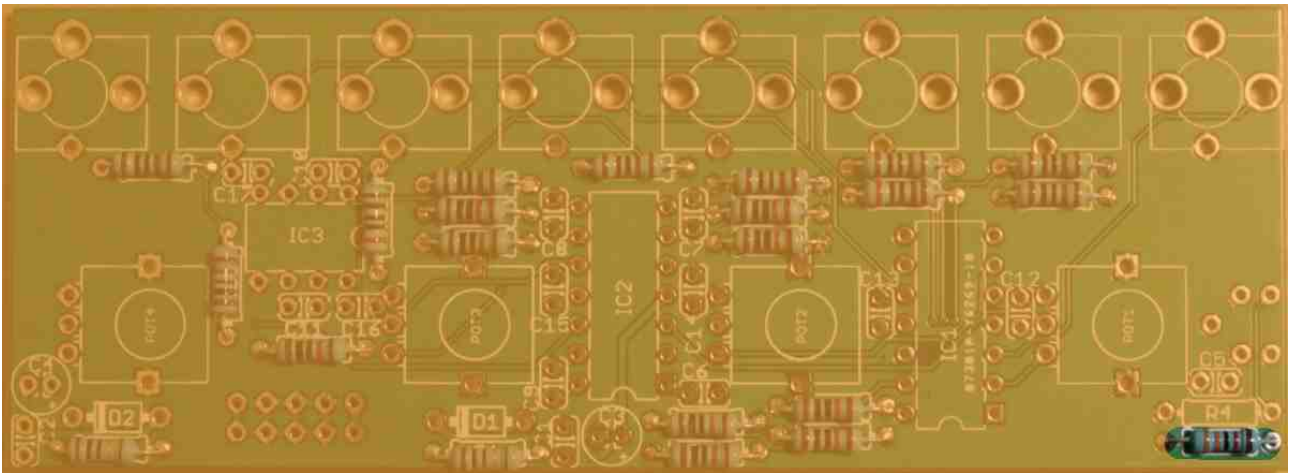

R3 33K

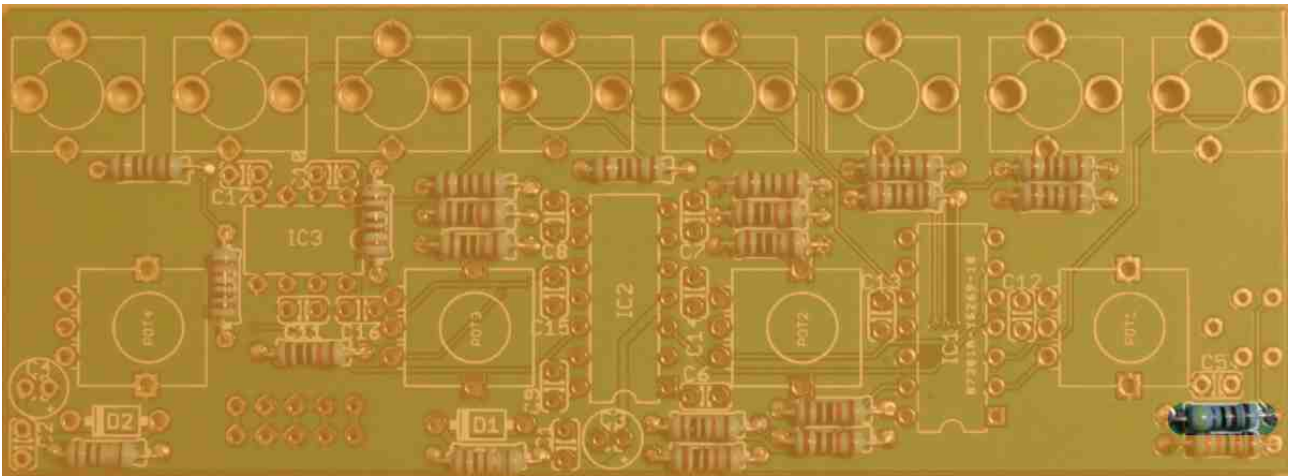

R4 4.7K

Step 2

Solder reverse polarity protection diodes. The stripe on the diodes must be on the same side as indicated in the silk screen.

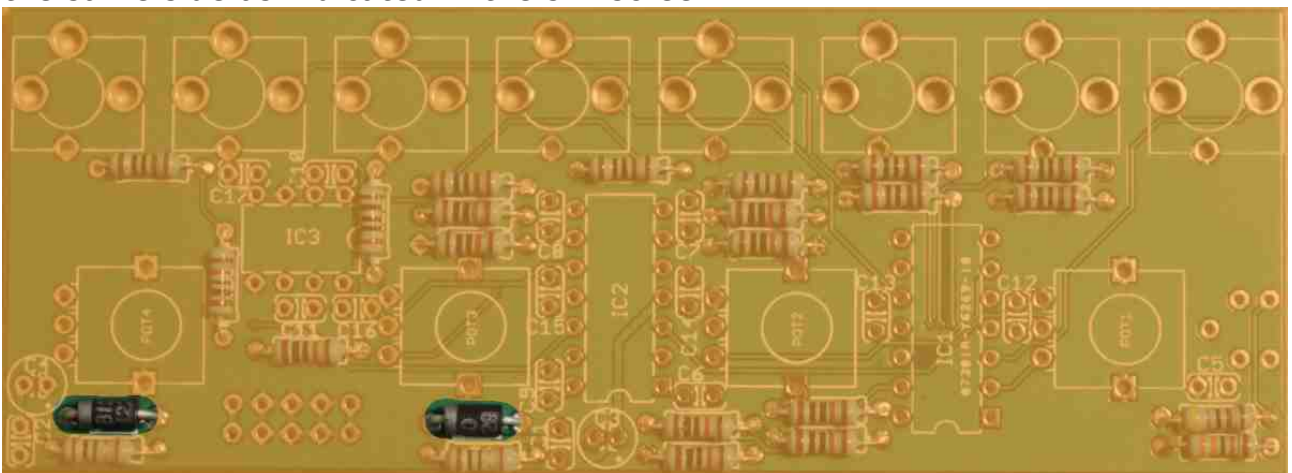

D1, D2 SB130

Step 3

Solder ceramic capacitors. Ceramic capacitors are not sensitive to mounting direction.

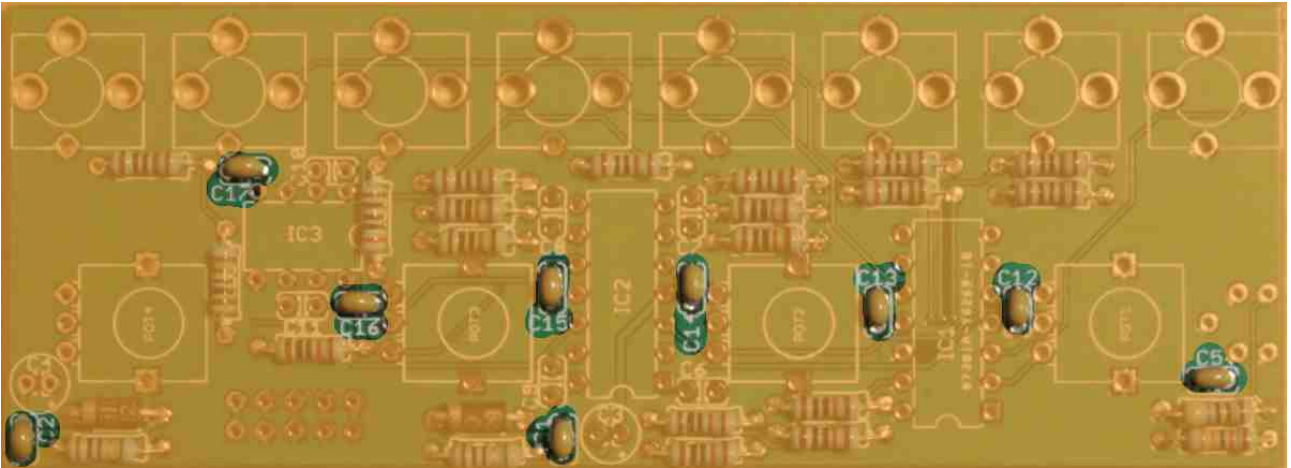

C1, C2, C5, C12, C13, C14, C15, C16, C17 100nF

Step 4

Solder sockets. Match the IC sockets indent (pin 1) with the silk screens. Don't mount the crossed over ceramic capacitors as they are unnecessary.

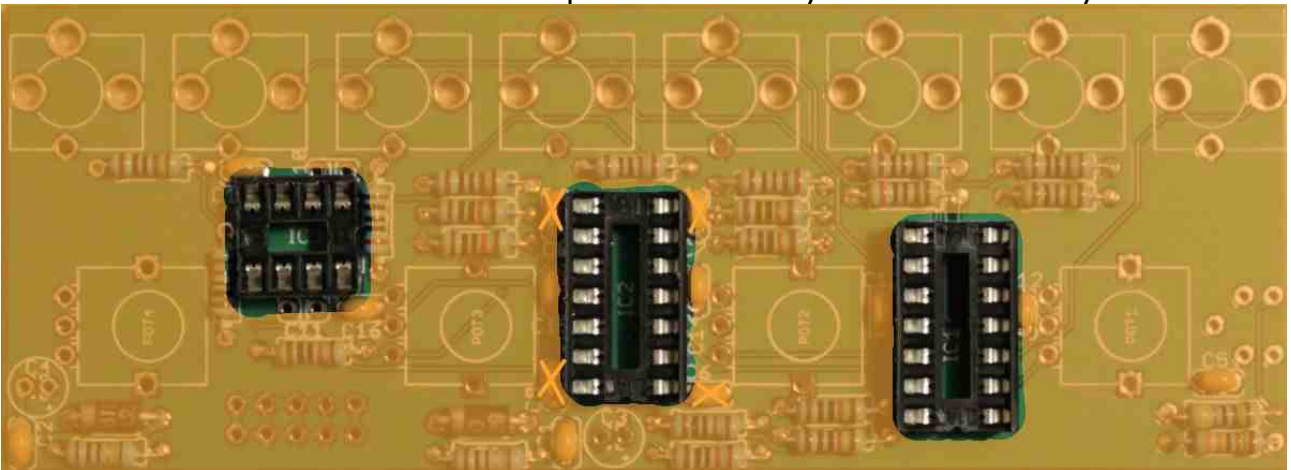

IC1, IC2, IC3 sockets. IC's will be mounted later.

Step 5

Solder Electrolytics. Long leg is + (anode).

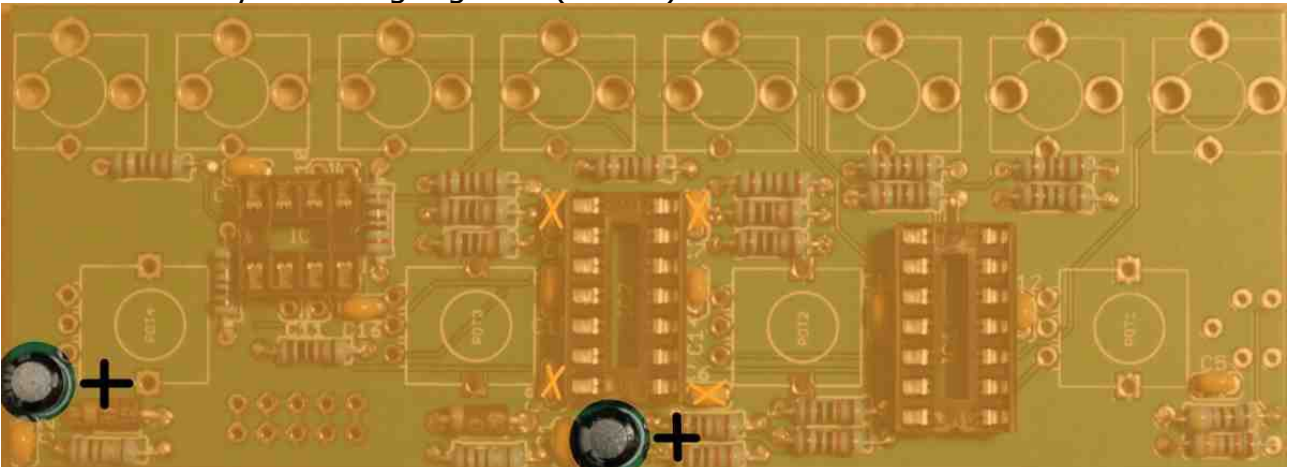

C3 10 μ F, **C4** 10 μ F

Step 6

Solder trimmer. Only 3 of the 5 holes are used, the extra 2 holes are for fitting trimmers with different appearance.

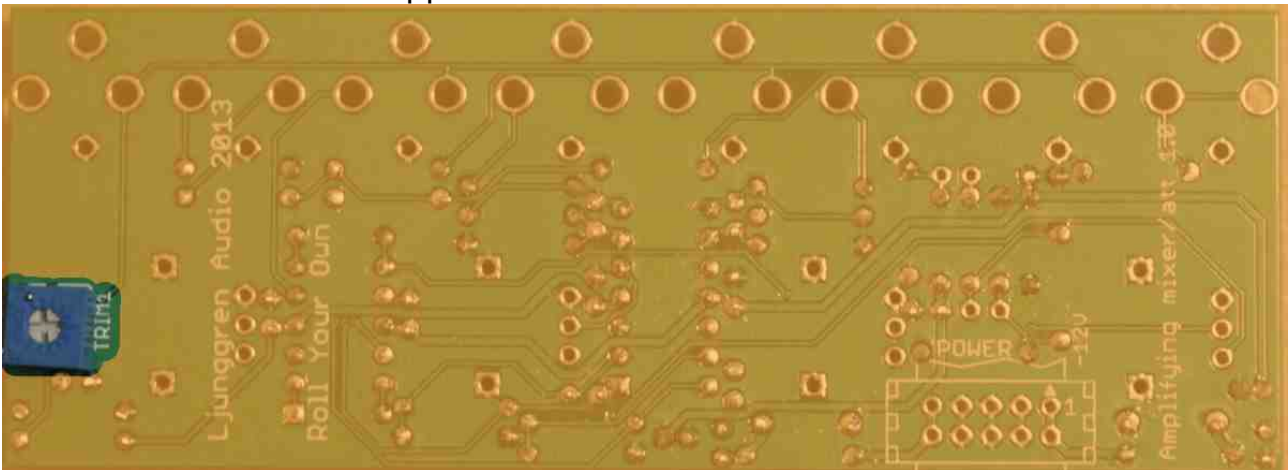

TRIM1 10K

Step 7

Solder the keyed boxed power header. Pay extra attention to the direction. The triangle (pin 1) must be at the -12V side. In the picture below you can see the direction of the keyed opening in the boxed header.

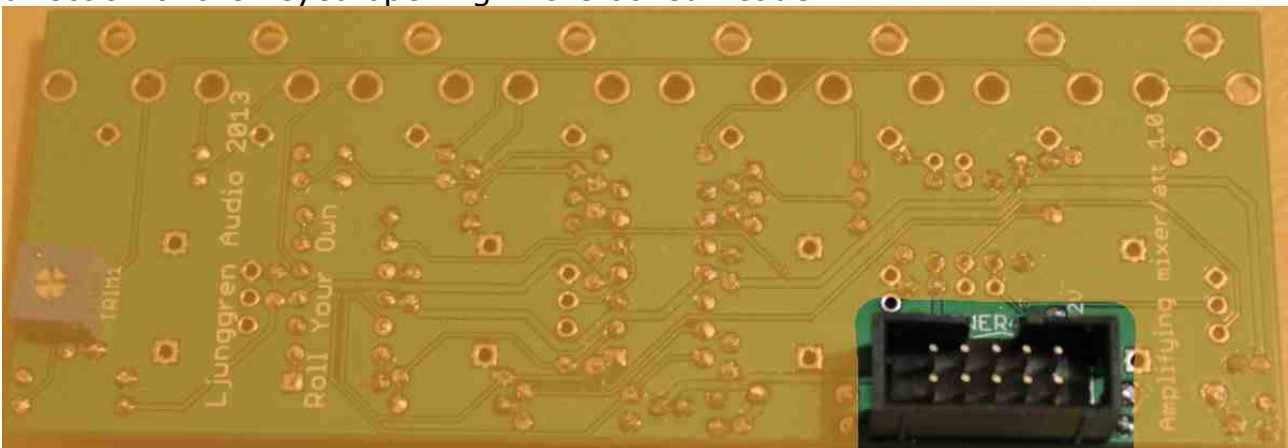

POWER

Step 8

Solder the jacks.

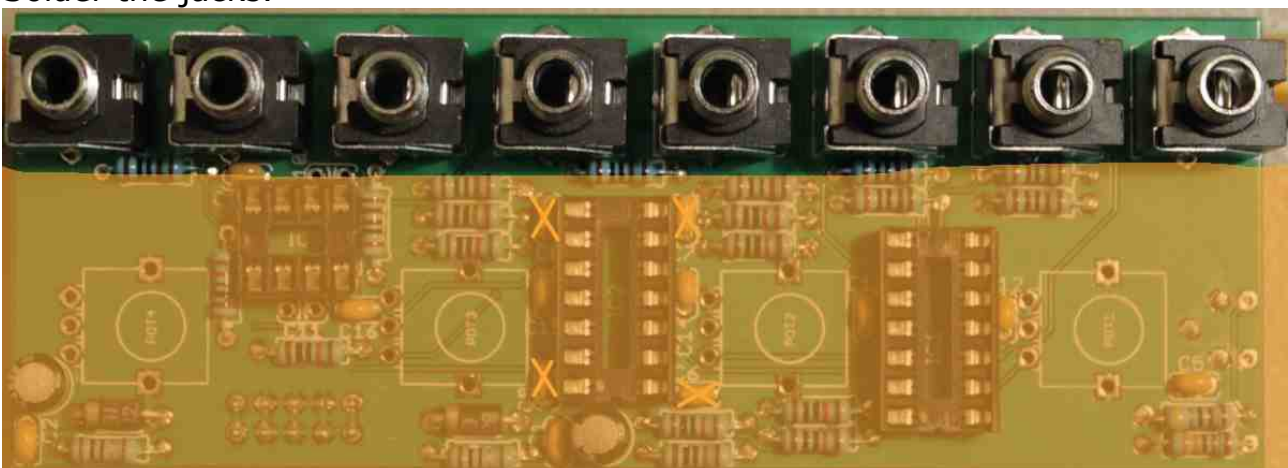

J1, J2, J3, J4, J5, J6, J7, J8 PJ301BM

Step 9

Remove the nuts and washers from the potentiometers. Cut off the small metal tab sticking out indicated by a circle below. Use a cheap plier/nipper for this step, save your fancy ones for other tasks.

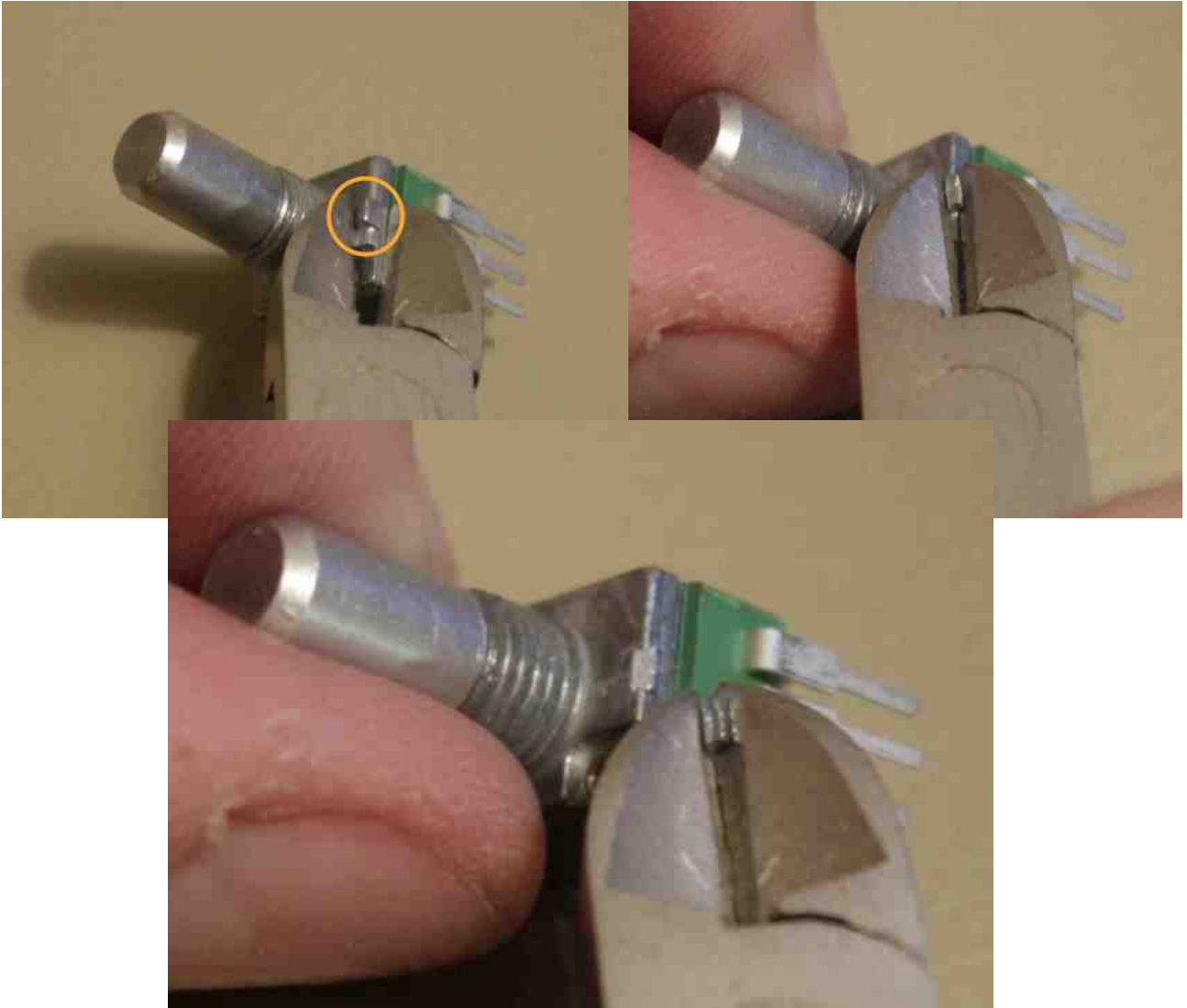

And solder them in place.

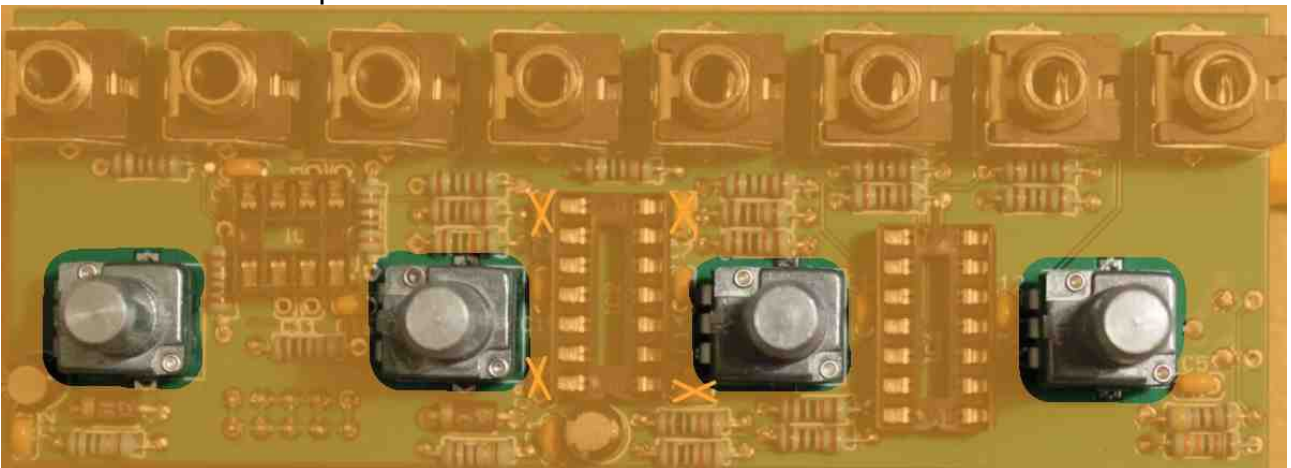

POT1, POT2, POT3, POT4 50K or 100K linear

Step 10

Mount the IC's. The IC's indent or dot marking pin 1 must match the silk screen direction.

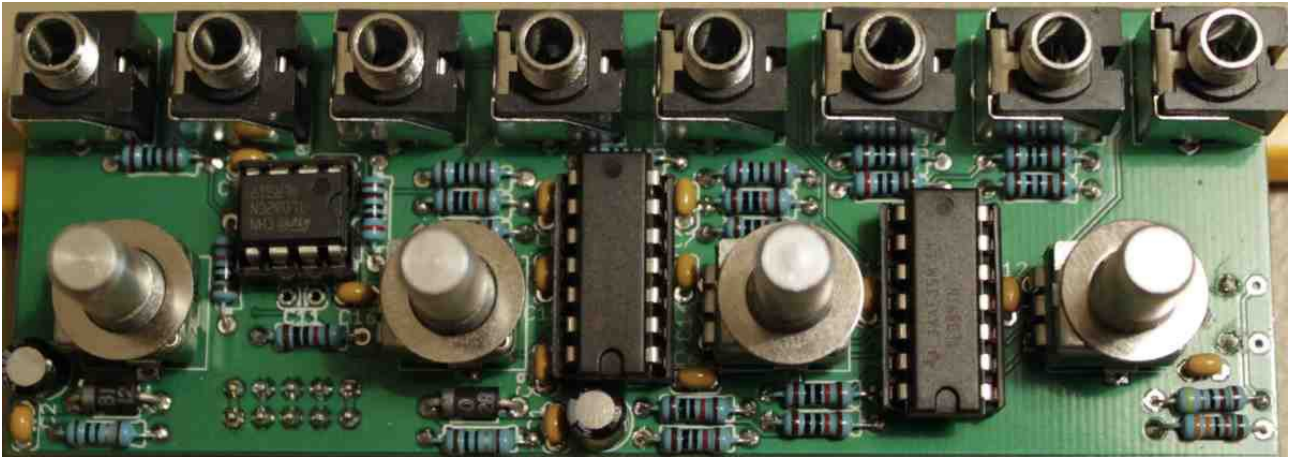

Step 11

Mount the panel. Use 8 mm wrench socket for the jacks and switch and 10 mm for the potentiometers.

Potentiometers: Use the washers that was originally attached to the potentiometers under the panel and the nut over the panel.

Jacks: No washers under the panel. One washer and one nut per jack over the panel.



Step 12

Mount the knobs on the potentiometers.



Step 13

Mount the power cable. Red stripe at -12V.

Finished module!



Calibration

1.
Turn channel 1 knob fully CW (right).
2.
Connect a patch cable to channel 1 output. Leave channel 1 input jack unconnected.
3.
Measure voltage with a multimeter between the tip and ring (signal and ground) of the patch cable.
4.
Adjust trimmer until you measure 5V on the multimeter.

There will be some small variations between the channels due to the use of 1% resistors and standard opamps with up to 6mV offset. If you use 0.1% resistors where the BOM say 1% and opamps with lower offset you will get better precision for offset, attenuating and mixing.

Although Ampmix have 1k isolation resistors on the outputs so if you patch them to inputs without resistorless buffers there will be a voltage droop and it will increase with passive multing.